

## **PLEASE READ**

This manual is provided as a free service by Projector.com.

We are in no way responsible for the contents of the manual. We do not guarantee its accuracy and we do not make any claim of copyright. The copyright remains the property of their respective owners.

## **ABOUT PROJECTOR.COM**

Projector.com (<http://www.projector.com>) is your review and buying guide resource for DLP and LCD video projectors.

Visit the site to read the latest projector news and reviews, read and comment on projector specifications, download user manuals and much more.

# 3M

# MP8625 Multimedia Projector

## Operator's Guide

*MP8625 Projecteur multimédia Guide de l'opérateur*

*MP8625 Multimedia-Projektor Benutzerhandbuch*

*Projector de Multimedia MP8625 Manual del Usuario*

*MP8625 Proiettore Multimediale Manuale dell'operatore*

*MP8625 Bruksanvisning för multimediprojektor*

*MP8625 Multimedia Projector Gebruiksaanwijzing*

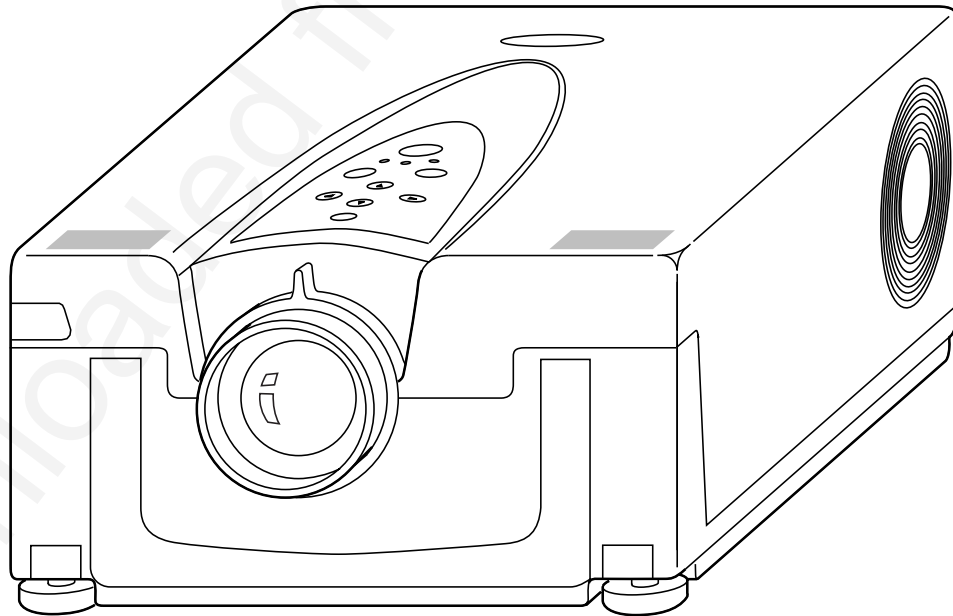





# Table of Contents

<b>Safeguards</b>	<b>1</b>
<b>Warranty</b>	<b>2</b>
<b>Section 1: Unpack</b>	<b>3</b>
1.1 Contents of Shipping Box	3
1.2 Optional Accessories	3
1.3 Keep Your Packing Materials	3
1.4 What's Next?	3
<b>Section 2: Product Description</b>	<b>4</b>
2.1 Machine Characteristics	4
2.2 Part Identification List	4
2.3 System Setup	5
2.4 Remote Control Transmitter Identification	6
<b>Section 3: Basic Operations</b>	<b>7</b>
3.1 Projector Startup	7
3.2 Projector Shutdown	7
<b>Section 4: Adjustments and Functions</b>	<b>8</b>
4.1 Menu Navigation	8
4.2 How To Use Height Adjustment Feet	9
4.3 SETUP	10
4.4 INPUT	11
4.5 IMAGE	12
4.6 OPT	13
<b>Section 5: Maintenance</b>	<b>14</b>
5.1 Cleaning the Air Filter	14
<b>Section 6: Lamp</b>	<b>15</b>
6.1 Lamp	15
6.2 Display Lamp Operation Hours	15
6.3 Replacing the Lamp	15
<b>Section 7: Troubleshooting</b>	<b>17</b>
7.1 Symptom/Solution Table	17
7.2 Message/Solution Table	17
7.3 Service Information	18
<b>Section 8: Accessories</b>	<b>18</b>
<b>Appendix: Technical Information</b>	<b>A.1</b>

Downloaded from Projector.com



# Safeguards

## INTENDED USE

Before operating the machine, please read the entire manual thoroughly. The 3M™ Multimedia Projector 8625 was designed, built and tested for use indoors, using 3M™ brand lamps, 3M™ brand ceiling mount hardware and nominal local voltages. The use of other replacement lamps, outdoor operation or different voltages has not been tested and could damage the projector or peripheral equipment and/or create a potentially unsafe operating condition.

## IMPORTANT SAFEGUARDS

1. Read and understand all instructions before using.  
Pay particular attention to areas where this ⚠ symbol is shown.

**⚠ WARNING** - Indicates a potentially hazardous situation which, if not avoided, could result in death or serious injury.

**⚠ Caution** - Indicates a potentially hazardous situation which, if not avoided, could result in minor or moderate injury. It may also be used to alert against unsafe practices.

**✓ Note** - Used to emphasize important conditions or details.

2. Close supervision is necessary when any appliance is used by or near children. Do not leave appliance unattended while in use.
3. Never look directly into the projector lens when the lamp is on. The metal halide lamp produces a strong light which could damage your eyesight.
4. Care must be taken as burns can occur from touching hot parts.
5. Do not operate appliance with a damaged cord or if the appliance has been dropped or damaged – until it has been examined by a qualified service technician.
6. Position the cord so that it will not be tripped over, pulled, or contact hot surfaces.
7. If any extension cord is necessary, a cord with a current rating at least equal to that of the appliance should be used. Cords rated for less amperage than the appliance may overheat.
8. Always unplug appliance from electrical outlet before cleaning and servicing and when not in use. Grasp plug and pull to disconnect.
9. To reduce the risk of electric shock, do not immerse this appliance in water or other liquids.
10. To reduce the risk of electric shock, do not disassemble this appliance, but take it to a qualified technician when service or repair work is required. Incorrect assembly can cause electric shock when the appliance is subsequently used.
11. Connect this appliance to a grounded outlet.
12. Do not expose this projector to direct sunlight, or use it outside.
13. Keep all ventilation openings free of any obstructions.
14. Always open the lens shutter when the projection lamp is on.
15. Do not look directly into light beam of laser pointer. The pointer produces a strong light which could damage your eyesight.
16. The projection lamp contains mercury. Always dispose of it in a proper manner according to local regulations.
17. To avoid premature lamp failure, do not change the mounting position of the projector (desktop ⇨ ceiling mount or ceiling ⇨ desktop mount) and continue to use the same lamp.
18. Always operate machine on a flat, sturdy surface.

## SAVE THESE INSTRUCTIONS

The information contained in this manual will help you operate and maintain your 3M MP8625 Multimedia Projector.



# Warranty

## LIMITED WARRANTY

3M warrants this product against any defects in material and workmanship, under normal usage and storage, for a period of two years from date of purchase. Proof of purchase date will be required with any warranty claim. In the event this product is found to be defective within the warranty period, 3M's only obligation and your exclusive remedy shall be replacement of any defective parts (labor included).

To obtain warranty service, immediately notify the dealer from which you purchased the product of any defects. In the USA call 1-800-328-1371 for warranty or repair service.

## LIMITATION OF LIABILITY

THE FOREGOING WARRANTY IS MADE IN LIEU OF ALL OTHER WARRANTIES, EXPRESSED OR IMPLIED, AND 3M SPECIFICALLY DISCLAIMS ANY IMPLIED WARRANTY OF MERCHANTABILITY AND FITNESS. 3M SHALL NOT BE LIABLE FOR ANY DAMAGES, DIRECT, CONSEQUENTIAL, OR INCIDENTAL, ARISING OUT OF THE USE OR INABILITY TO USE THIS PRODUCT.

**Important:** The above warranty shall be void if the customer fails to operate product in accordance with 3M's written instructions. This warranty gives you specific legal rights and you may have other rights which vary from state to state.

## REGULATORY NOTICES

**FCC STATEMENT - CLASS A:** This equipment generates, uses and can radiate radio frequency energy, and if not installed and used in accordance with the instruction manual may cause interference to radio communications. It has been tested and found to comply with the limits for a Class "A" computing device pursuant to Subpart B of Part 15 of the FCC Rules, which are designed to provide reasonable protection against such interference when operated in a commercial environment. Operation of this equipment in a residential area is likely to cause interference in which case the user at his/her own expense will be required to take whatever measures may be required to correct the interference.

**EEC STATEMENT:** This machine was tested against the 89/336/EEC (European Economic Community) for EMC (Electro Magnetic Compatibility) and fulfills these requirements.

**Video signal cables:** Double shielded coaxial cables (FCC shield cable) must be used and the outer shield must be connected to the ground. If normal coaxial cables are used, the cable must be enclosed in metal pipes or in a similar way to reduce the interference noise radiation.

**Video inputs:** The input signal amplitude must not exceed the specified level.

## PATENT / COPY INFORMATION

IBM is a registered trademark of **International Business Machines Corporation**. **Apple Macintosh** and **Apple Powerbook** are registered trademarks of **Apple® Computer, Inc.** Microsoft and Windows 95 are registered trademarks, and Windows and Windows for Work Groups are trademarks of the **Microsoft Corporation**. **Toshiba** is a registered trademark of **Toshiba Corporation**. **Kensington** is a trademark of **Kensington Corporation**. All other products are trademarks or registered trademarks of their respective companies.



# Section 1: Unpack

## 1.1 Contents of Shipping Box

The 3M™ MP8625 Multimedia Projector is shipped with the necessary cables required for standard VCR, PC, MAC™ II or laptop computer connections. Carefully unpack and verify that you have all of the items shown below in Figure 1.1.

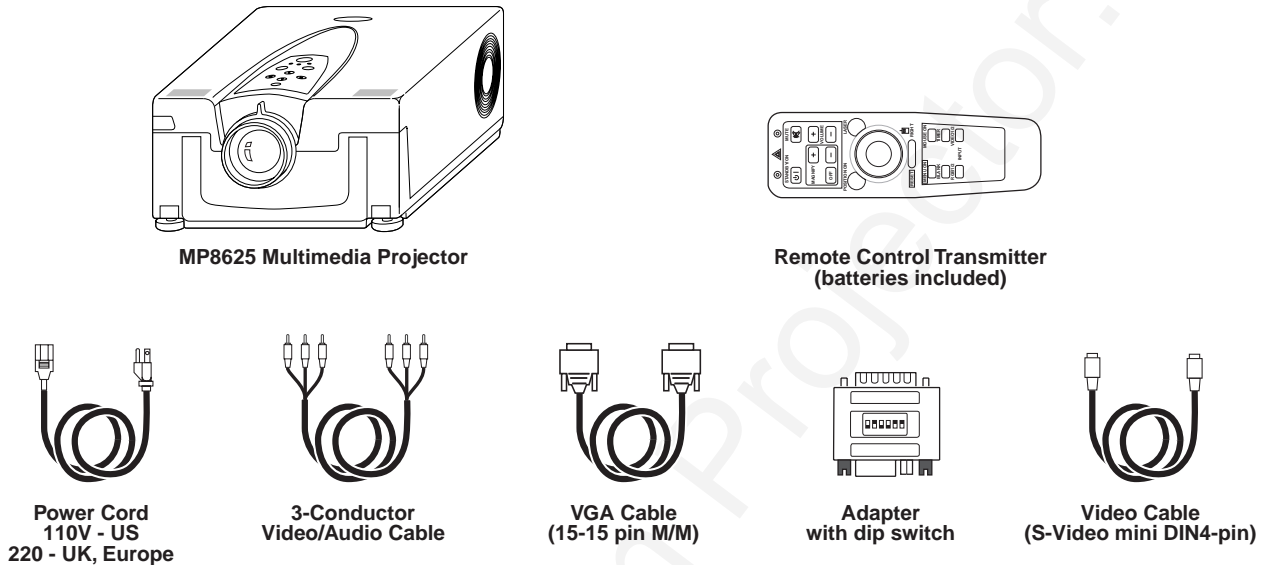

Figure 1.1 Inventory of Shipping Box

The shipping carton contains the items illustrated in Figure 1.1. In addition, the following items are also included, but not shown here. If any of these items are missing, please contact your place of purchase.

- PS/2 mouse cable ..... (1)
- ADB mouse cable ..... (1)
- Serial mouse cable ..... (1)
- Stereo mini-jack ..... (1)

## 1.2 Optional Accessories

- RS-232 control cable ..... (1)

## 1.3 Keep Your Packaging Materials

### ✓ Important

Save the shipping box and packing materials in the event the MP8625 should require shipping to a 3M Service Center for repair.

## 1.4 What Next?

After you have unpacked the MP8625 system and identified all the parts, you are ready to set up the projector.

We hope you will enjoy using this high performance product in your meetings, presentations and training sessions.

This product has been produced in accordance with 3M's highest quality and safety standards to ensure smooth and trouble free use in the years to come.



## Section 2: Product Description

### 2.1 Machine Characteristics

The MP8625 Multimedia Projector integrates ultra-high performance lamp and polysilicon LCD display technology into a single unit. It accepts input from two different computer sources and two video/audio sources and projects a bright, super crisp image. Switching your presentation from a computer input to a video input, and then back to a computer input simply requires the push of a button on the remote control keypad or control panel keypad.

The MP8625 Multimedia Projector offers the following features:

- Ultra-high performance projection lamp
- SVGA resolution (3 separate 800 x 600 LCD panels are used for the R, G and B signals)
- Advanced Genesis™ XGA scaling (60 Hz and 75 Hz)
- Advanced Genesis™ VGA scaling
- Compact size, light weight for portability
- RGB (computer video) output terminal
- Serial, PS/2 and Apple© Desktop Bus (ADB) mouse emulation
- Manual zoom and manual focus functions
- Easy to set up and use
- Ability to display 16.7 million colors
- Two computer input connections
- Two video input connections (composite and S-video compatible)
- Full function remote control
- Two built-in stereo speakers (1 watt each)
- Horizontal and vertical image inverting function
- Horizontal and vertical image position control
- Fixed keystone correction
- On screen menu with seven languages
- Universal power supply
- IR sensor in front and rear for maximum remote control range
- RS-232 control capability
- Optional ceiling mount kit
- Laser pointer (remote control)
- Color balance control for data/video
- Kensington™ lock  (Kensington microsaver needed)
- Mounting holes for optional document camera

#### ✓ Note

The MP8625 is one of the brightest projectors in the marketplace. The brightness of your machine will vary depending on the ambient room conditions and contrast/brightness settings.

### 2.2 Part Identification List

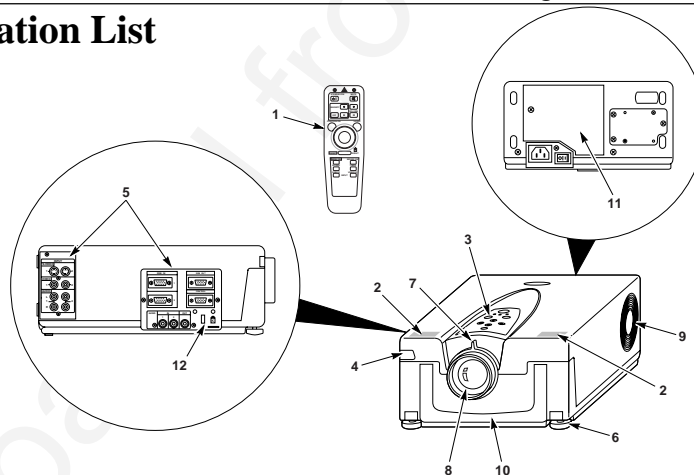

Figure 2.1 Identifying MP8625 Parts

1. Remote control transmitter
2. Stereo speakers
3. Control Panel Keypad
  - a) STAND BY/ON button
  - b) ON, LAMP, TEMP, Indicator
  - c) INPUT, MUTE, RESET buttons
  - d) MENU buttons
4. Remote Control Sensors (front/back)
5. Terminal Connection Panels
  - a) S-Video, Video, Audio inputs
  - b) RGB1 and RGB2 inputs
  - c) RGB output
  - d) Audio L/R input, Audio output (stereo mini jack)
  - e) RS-232 Control
  - f) AC input-power cord connection
  - g) Main power switch
6. Height Adjustment Feet
7. Lens shutter (open/closed)
8. Projection lens
9. Cooling fan exhaust
10. Carry handle
11. Lampdoor
12. Kensington™ Lock

## 2.3 System Set Up - connecting various equipment

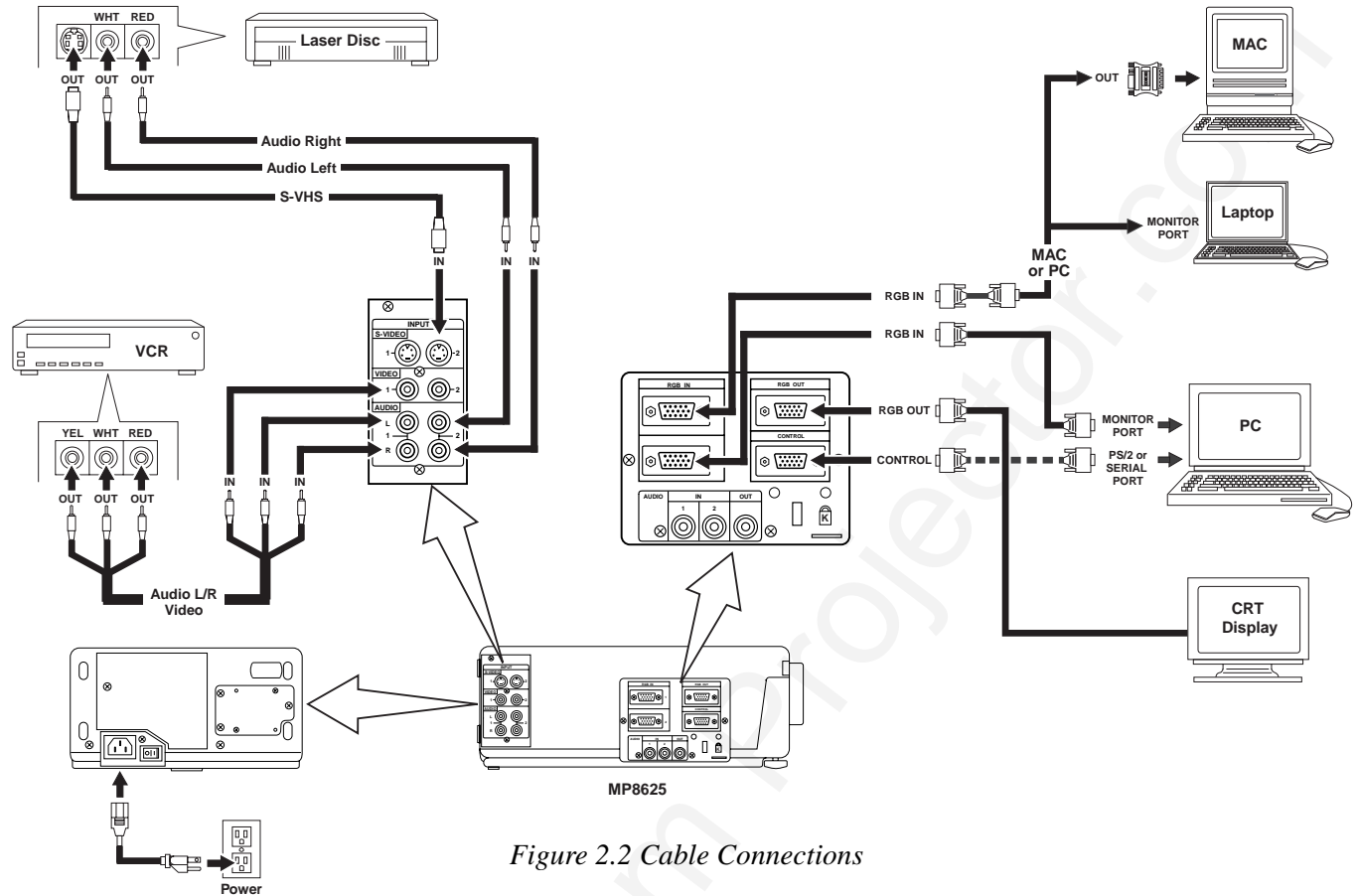

Figure 2.2 Cable Connections

### ⚠ Caution

Turn power off to all devices before making connections. Never plug anything into the projector or computer while any device is in operation.

The MP8625 must be powered down when making connections. The mouse emulation may not work if the unit is not powered down before the mouse cable connections are made.

**2.3.1 Apple™ Desktop Mouse** - The Macintosh operating system should recognize the MP8625 as a mouse without any drivers being loaded.

**VirtualMouse for PC Computer** - For IBM™ compatible computers, the operating systems will need to be set to "Serial Mouse" or "PS/2 Mouse" to recognize the projector as a mouse pointer device

Change mouse driver information to "Serial Mouse" or "PS/2 Mouse."

- a) **Windows™ 95/Windows™ 98** - Click "Start"; select "Settings"; select "Control Panel". Click on "Mouse"; select the "General" tab; (see what driver is currently loaded and make note of it); select "Change"; select "Show all devices"; (make note of the current Manufacturer and Model); select "Standard Mouse Type" for Manufacturer; then select "Standard Serial Mouse" or "Standard PS/2 Mouse." Click OK to change and apply the new driver. Restart Windows when prompted.
- b) **Windows™ 3.1** - From "Program Manager" click "Main"; then click "Windows Setup", (make note of what the current mouse driver is); Click "Options"; then "Change Systems Settings". Choose "Mouse". It should be listed as "Microsoft or IBM PS/2".

### ✓ Note

For proper mouse operation, always turn the projector power on first and then power up the computer.

For some laptop computers you may need to disable the internal pointing device (IPD). This is done through the BIOS level set up of the particular machine, or it could be listed in a "Utilities" program group, i.e., "Toshiba Utilities™," or "Thinkpad Features™."

## 2.4 Remote Control Transmitter Identification

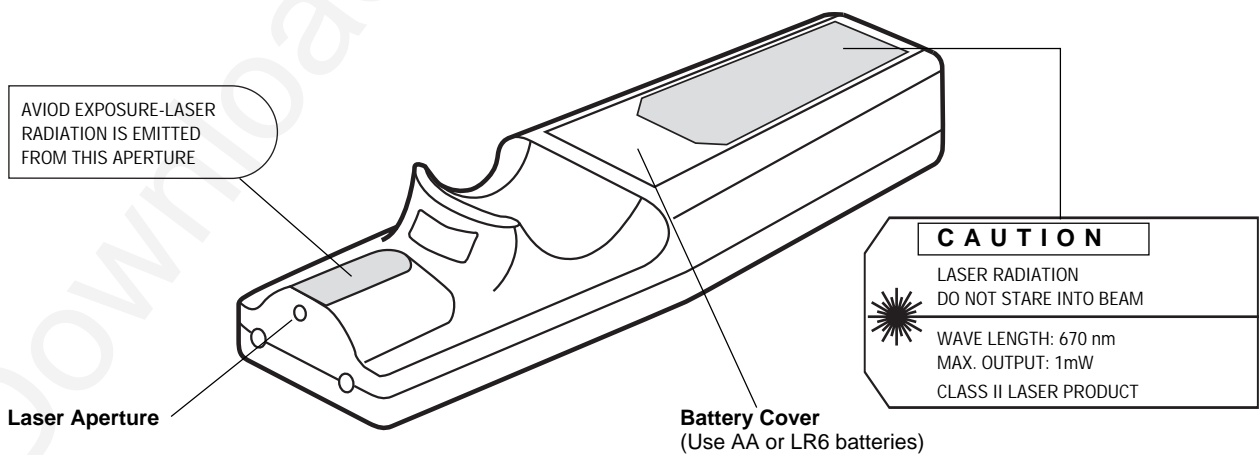
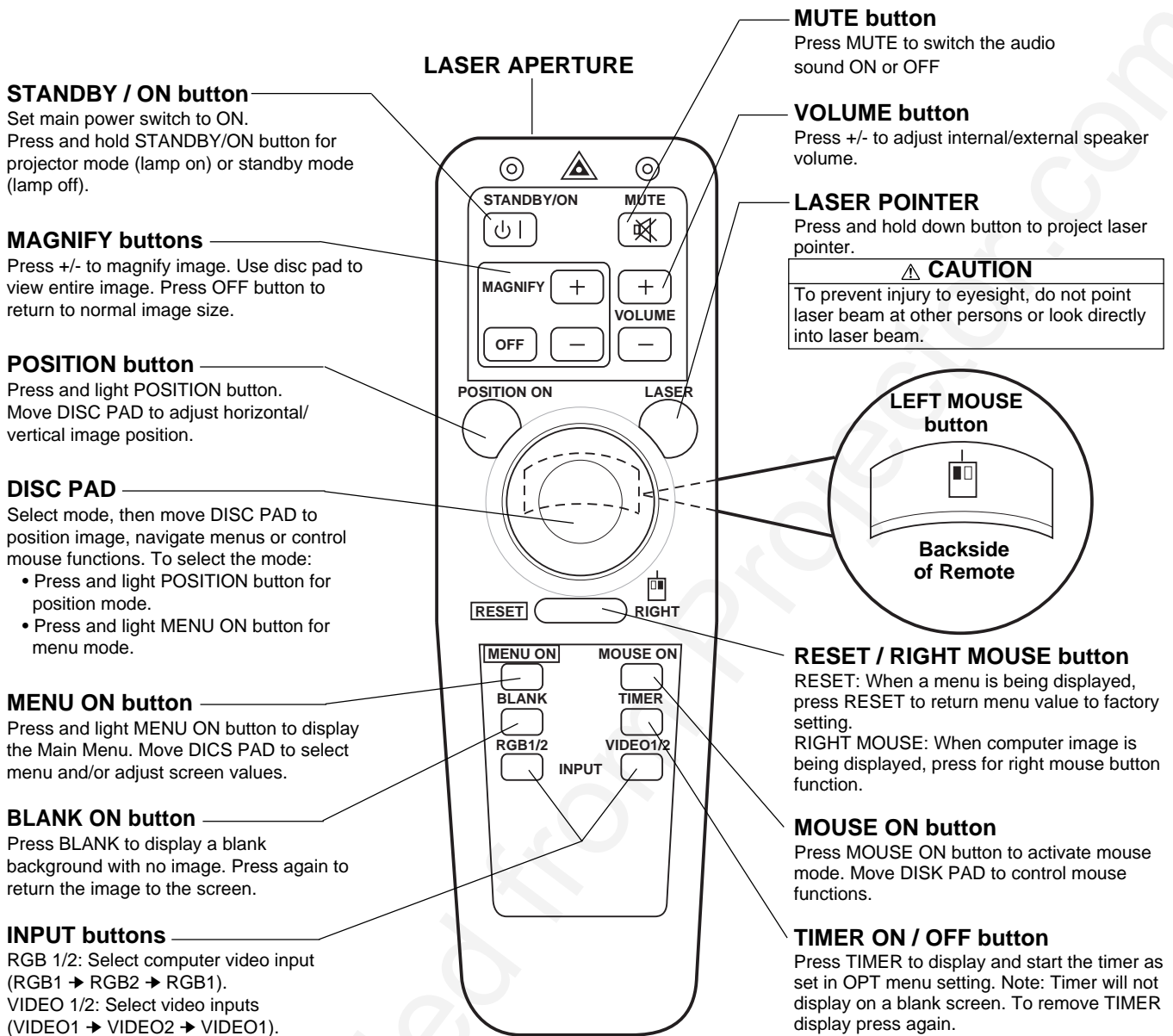

Figure 2.3 Remote Control Buttons



## Section 3: Basic Operations

### 3.1 Projector Startup

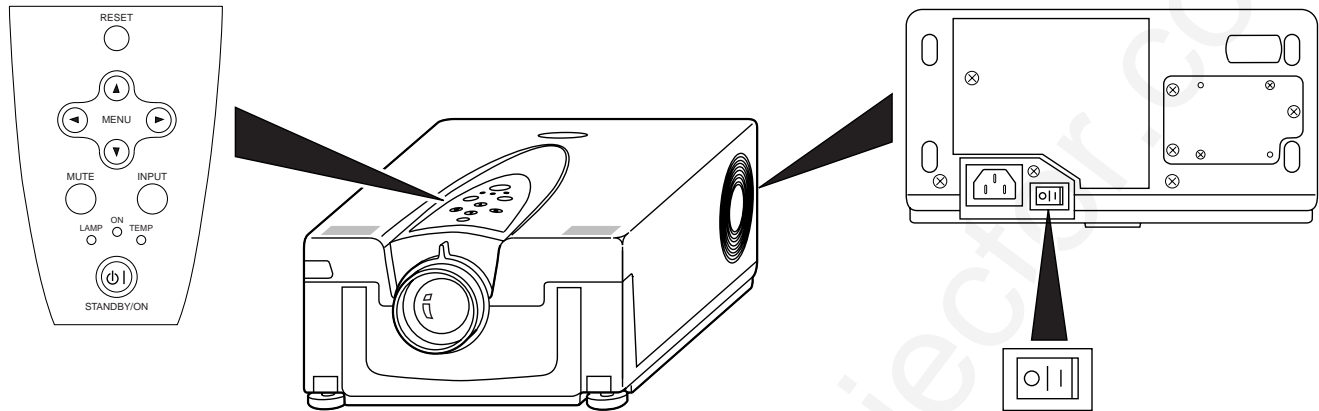







Figure 3.1 Projector Controls

1. **Make all cable connections and line hookups with the power off.**
2. **Turn the POWER SWITCH  of the projector on.** The ON indicator will light up orange.
3. **Press the STANDBY/ON button .** The ON indicator blinks (green) and then lights (green). The ON indicator will blink green during warm-up and lamp ignition.
4. **Adjust the screen size by rotating the ZOOM CONTROL.**
5. **Adjust the focus by rotating the projection lens.**
6. **Turn on all connected equipment.** The method of connecting various equipment, see section 2.3.
7. **Press the INPUT button  on the projector or the INPUT SELECT (VIDEO or RGB) button on the remote to select the source of the signal to be projected on the screen.** The selected signal input is displayed at the bottom right of the screen. The display will show the **last selected input source** before power was turned off.

### 3.2 Projector Shutdown

1. **Hold the STANDBY/ON button  for 3-5 seconds.** The ON indicator blinks orange and the lamp turns off. After approximately 1 minute, the fan stops and the indicator stays orange.
2. Turn the **MAIN POWER SWITCH  of the projector off.**

#### **Caution**

Do not turn off the POWER SWITCH before pressing the STANDBY/ON button. After the STANDBY/ON button is pressed, the fan rotates for about 1 minute to cool the projector.

3. **Disconnect cables.**



## Section 4: Adjustment and Functions

### 4.1 Menu Navigation

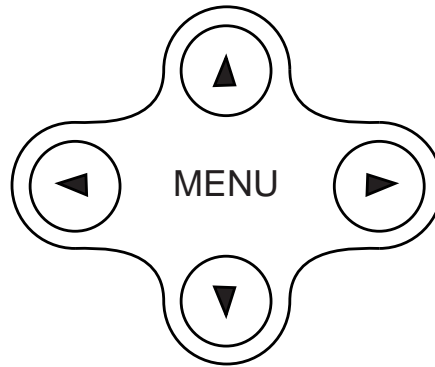

Figure 4.1 Menu Button

1. **Press any MENU button on projector or remote control MENU button.**  
On-screen menus are displayed on the screen.
2. **Select the menu to be adjusted using the MENU (◀ ▶) buttons or DISC PAD.**  
Selected Menu is highlighted.
3. **Select the item to be adjusted using the MENU (▲ ▼ ◀ ▶) buttons or DISC PAD.**  
Highlighted items may be adjusted.

✓ Note

Separate settings are provided for the VIDEO1, VIDEO2, RGB1 and RGB2 input terminals. Adjustments are saved after power off.

### Factory Default Setting:

1. **Highlight SETUP option.**
2. **To reset the entire SETUP menu**
  - Press the RESET button.
  - Select DEFAULT or CANCEL.
3. **To reset a single item from SETUP menu**
  - Select the adjustment item (brightness, contrast...)
  - Press the RESET button. **Only the selected item resets.**

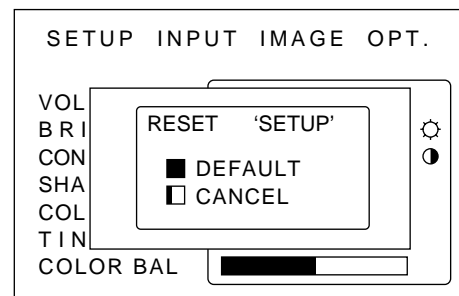

Figure 4.2 Default Settings

## 4.2 How To Use Height Adjustment Feet

Adjust the image elevation using the height adjustment at the front of the projector.

1. Raise the front end of the projector so the feet are not touching the table top.
2. Push the lock button to unlock the foot.
3. Extend or retract each foot to the desired height.
4. Release the lock button to lock the foot into position.
5. For fine adjustments, rotate each foot.

### Caution

Do not unlock the foot adjusters if the projector is not supported. If the foot adjusters do not lock completely, turn the foot adjusters slightly before locking.

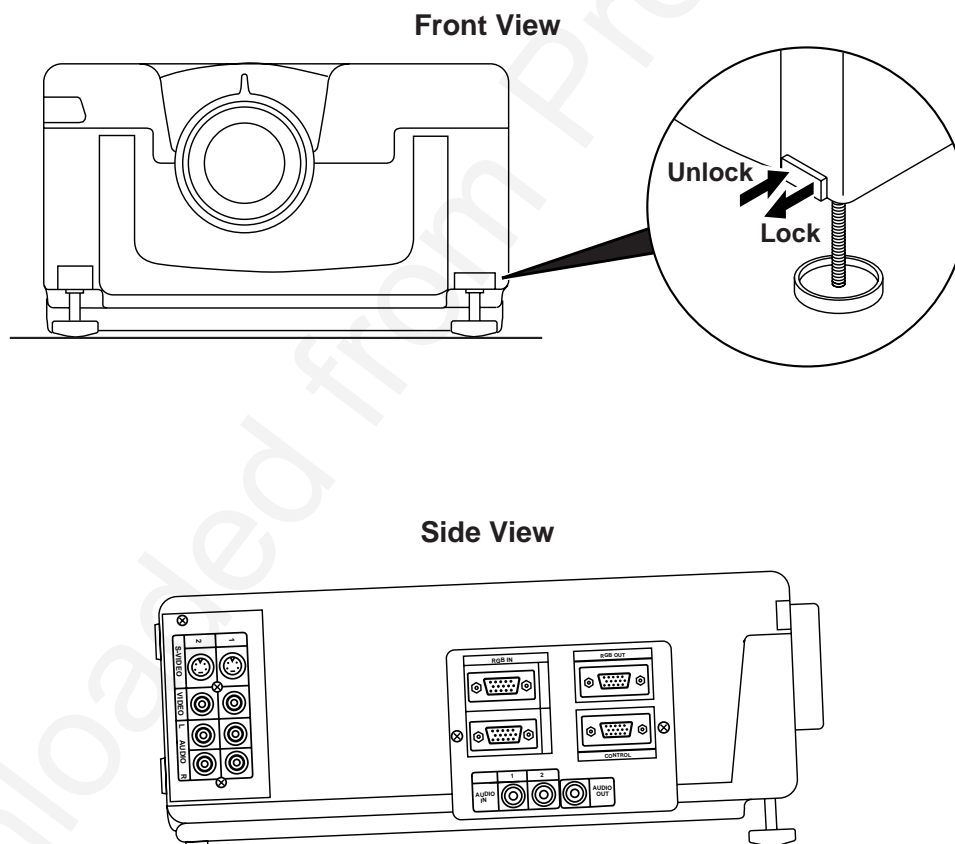

*Figure 4.3 Height Adjustment*

## 4.3 SETUP

The SETUP sub-menu is used to adjust and move the image position. The projector will display either the RGB (Figure 4.4) or Video (Figure 4.5) menu according to the input source being projected.

RGB signal input

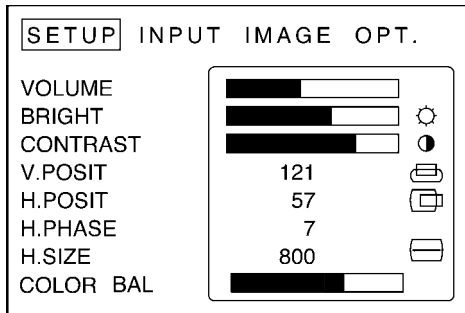

Figure 4.4 RGB Signal

Video signal input

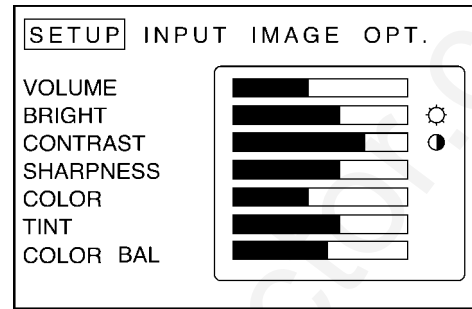

Figure 4.5 Video Signal

Adjustment Item	Details of adjustment	Default
<b>VOLUME</b>	Decrease ← → Increase	
<b>BRIGHT (BRIGHTNESS)</b>	Dark ← → Bright	
<b>CONTRAST</b>	Lower ← → Higher	
<b>SHARPNESS</b>	Soft ← → Sharp	
<b>COLOR</b>	Less ← → More	
<b>TINT</b>	Red ← → Green	
<b>V.POSIT (V.POSITION)</b>	Moves the picture up or down.	
<b>H.POSIT (H.POSITION)</b>	Moves the picture left or right.	
<b>H.PHASE</b>	Decreases the picture flicker	
<b>H.SIZE</b>	Widens or Narrows the horizontal size of picture	
<b>COLOR BAL</b>	Red ← → Blue	

### ✓ Note

- TINT cannot be adjusted with a PAL or M-PAL video signal input.
- TINT, COLOR and SHARPNESS cannot be adjusted with an RGB signal input.
- V. POSIT, H. POSIT, H. PHASE and H. SIZE cannot be adjusted with a VIDEO signal input.

## 4.4 INPUT

The menu INPUT sub-menu (Figure 4.6) is used to select the input source. The VIDEO1 and VIDEO2 values (Figure 4.7) have additional values that can be selected.

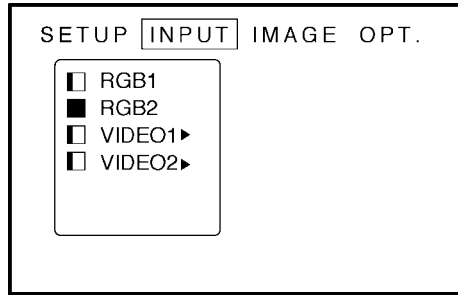

Figure 4.6 Input Menu

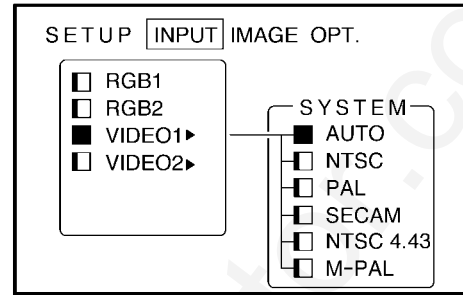

Figure 4.7

Adjustment Area	Value	Value Screen	Value
RGB1	Selects the RGB1 terminal		
RGB2	Selects the RGB2 terminal		
Video1	Select the VIDEO1 or VIDEO2 terminal	System	Selects the video signal format Auto, NTSC, PAL, SECAM, NTSC 4.43, M-PAL
Video2			



## 4.5 IMAGE

The IMAGE sub-menu is used to change the image characteristics.

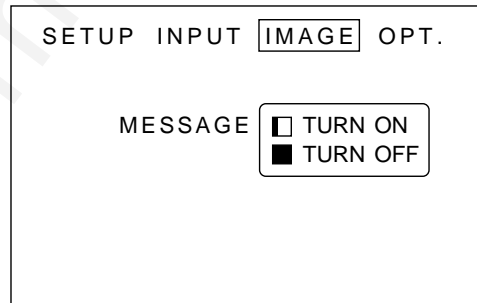
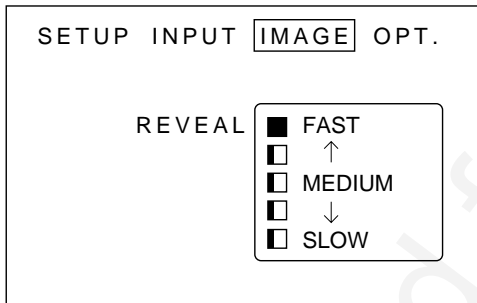
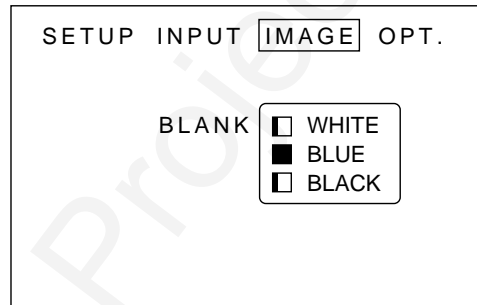
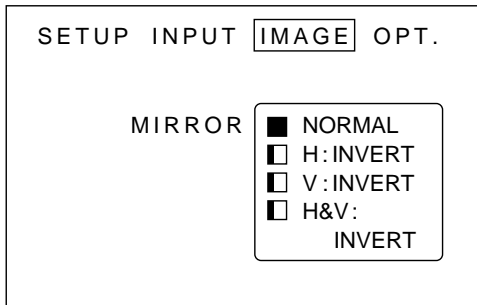
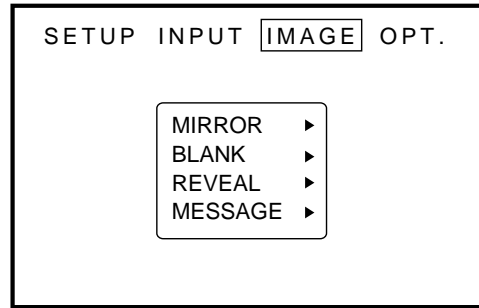

Figure 4.8 Image Adjustment Screens

Adjustment Screen	Value
<b>MIRROR</b>	Inverts the picture horizontally or vertically. H : INVERT Inverts the picture horizontally. V : INTERT Inverts the picture vertically. H&V: INVERT Inverts the picture horizontally and vertically.
<b>BLANK</b>	Selects the blank color.
<b>REVEAL</b>	Selects reveal speed.
<b>MESSAGE</b>	Turn ON or OFF on-screen messages.

## 4.6 OPT

The OPT. sub-menu allows you to control communication function.

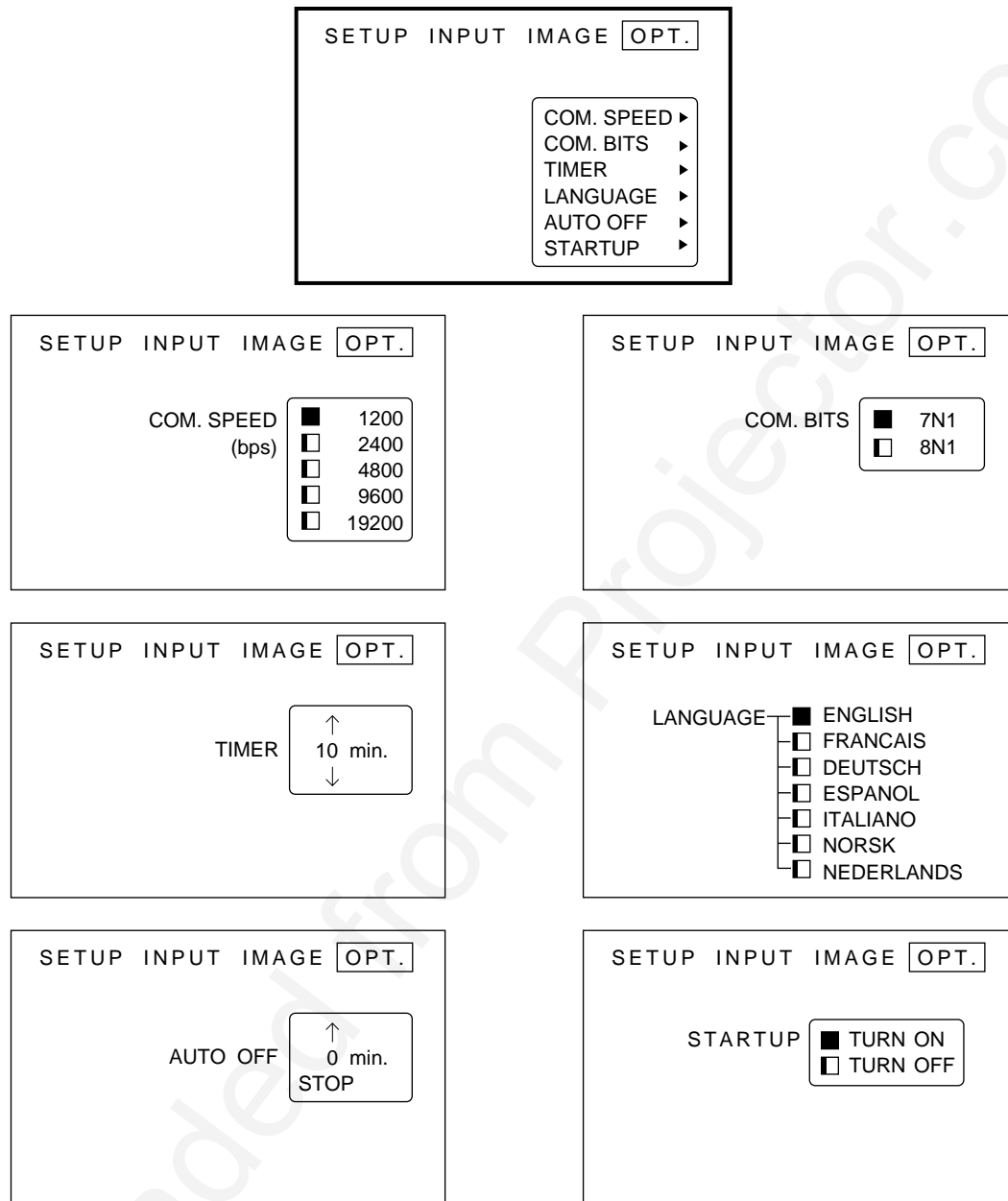

Figure 4.9 OPT Adjustment Screens

ADJUSTMENT SCREEN	VALUE	DEFAULT
COM. SPEED	Selects the data speed of transmission. (For mouse emulation-1200)	1200
COM. BITS	Selects the data format of transmission. 7N1... 7 data-bits, No parity, 1 stop bit. (For mouse emulation-7N1) 8N1... 8 data-bits, No parity, 1 stop bit.	7N1
TIMER	Sets the timer (in minutes).	—
LANGUAGE	Selects the language on-screen menu. (English, French, German, Spanish, Italian, Norwegian, Dutch)	—
AUTO OFF	Selects how long projector will stay on, if no input is detected. Select 0 to disable this function.	—
START UP	Enable/Disable Startup Screen.	TURN ON



## Section 5: Maintenance

### 5.1 Cleaning the Air Filter

✓ **Note**

Clean the air filter about every 50 hours.

1. Turn off the **MAIN POWER** switch of the projector and pull out power cord. Let cool for 20 minutes.
2. Remove the air filter from the bottom of projector. Unscrew retaining screw (1) and pull down and out (2) on the handle to free air cleaner door. Lift air filter door up and out (3) and set it aside.

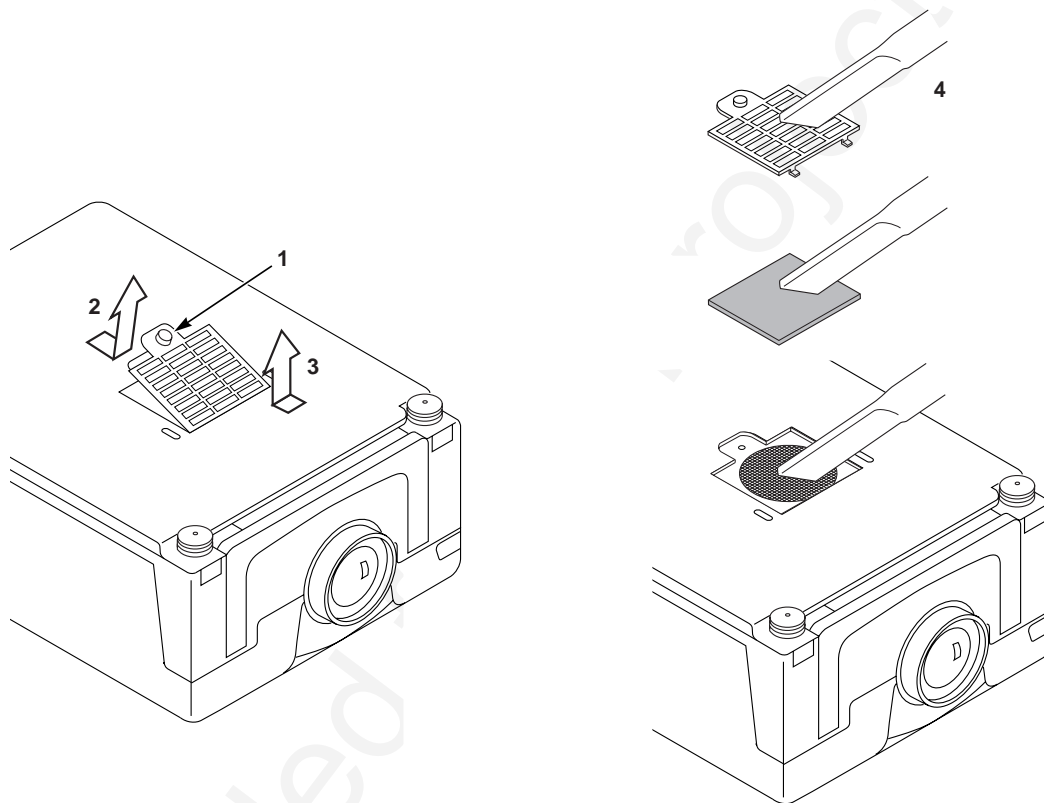

Figure 5.1 Remove Air Filter

3. Carefully remove foam air filter Screen (4) and clean foam screen and metal screen using a vacuum cleaner.
4. Re-install the air filter and replace the air filter door.

✓ **Note**

If air flow is restricted due to dust accumulation on filter, the projector may shut down due to over heating.



## Section 6: Lamp

### 6.1 Lamp

The following symptoms may indicate a lamp in need of replacement:

- LAMP indicator lights up red.
- "CHANGE THE LAMP" message appears on the screen.

---

✓ Note

This lamp contains mercury. Consult your local hazards waste regulations and **dispose of this lamp in a proper manner.**

---

### 6.2 Display Lamp Operation Hours

To determine the lamp operation hours, follow these steps:

1. While the projector is running, press and hold the timer button on the remote control for 3 seconds.
2. The operating time of the lamp will be displayed. If the operating hours are greater than 1,900 the "CHANGE THE LAMP, CALL A MAINTENANCE PERSON" message will appear. If the hours are greater than 1,980 the following message will appear, "POWER WILL TURN OFF AFTER **20 HOURS**" The number of hours left until shut down will decrease until **0** hour is reached, then power will be turned off.

---

✓ Note

After 2000 hours, the projector will only run for 10 minute intervals when restarted until the lamp is replaced and the lamp timer is reset. The message "CHANGE THE LAMP" will blink at projector start up to remind you to change the lamp.

---

3. To reset the timer, press the reset button and select **0** (or CANCEL). The "CHANGE THE LAMP" message will not come up if the timer is reset.

## 6.3 Replacing the Lamp

### ⚠ WARNING

Always turn off and unplug projector when changing lamp.

Lamp and adjacent metal parts become extremely hot and can cause severe burns to your fingers. Allow the projector to cool for at least 30 minutes before replacing the lamp.

1. **Remove lamp access door:** The lamp access door is located on the back of the machine on the right side. Use screwdriver to unscrew the cover retaining screw (1) and gently open the cover and set it aside.
2. **Retaining screws:** Use a screwdriver to unscrew the lamp module retaining screws. (2)

### ✓ Note

There are three lamp module screws that must be loosened. These screws are self-containing screws that cannot be removed from the lamp module or access door.

3. **Remove lamp module:** Grasp the lamp module with one hand and the projector body with the other hand. Carefully slide the lamp module out (3) using steady pressure.
4. **Insert lamp module:** Carefully insert (4) the new lamp module. Ensure that it is fully seated. Tighten the lamp module retaining screws (2) to secure the lamp module in place.  
Insert the hinge tabs on the left side of the lamp access door, then close and tighten the retaining screw (1) to secure the door.

### ✓ Note

Reset the lamp operation hours. See section 6.2 for details.

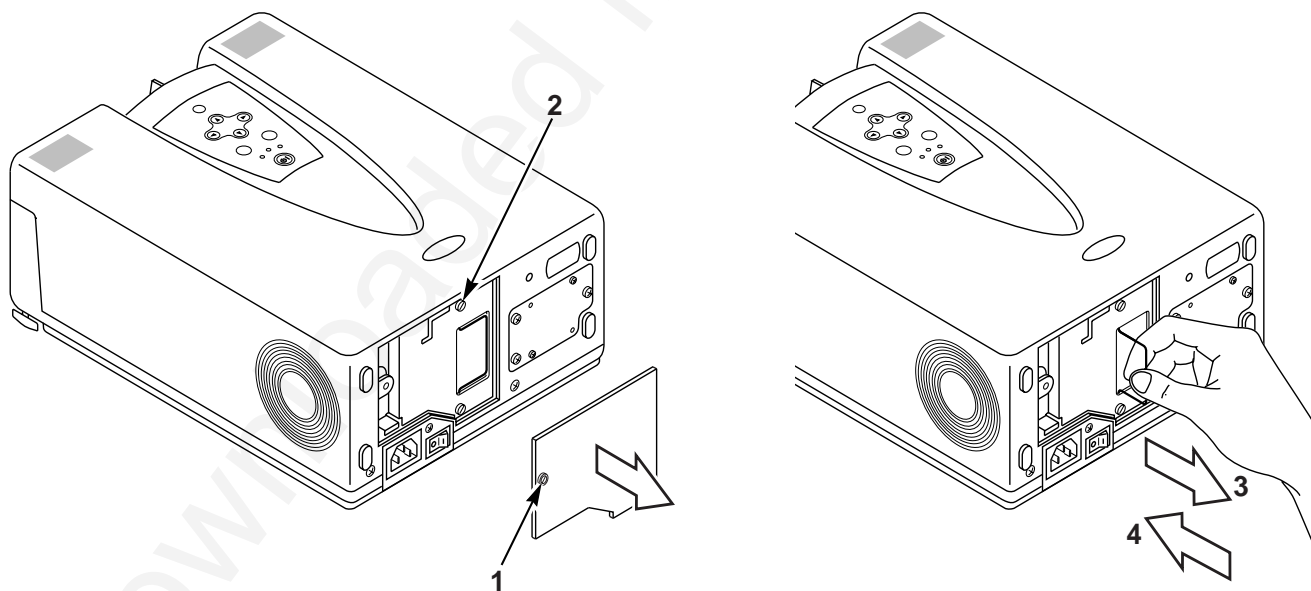

Figure 6.2 Lamp Module



# Section 7: Troubleshooting

## 7.1 Symptom/Solution Table

Symptom	Cause	Solution
Power cannot be turned on.	<ul style="list-style-type: none"> <li>The Main power is not turned on.</li> <li>The power cord is disconnected.</li> </ul>	<ul style="list-style-type: none"> <li>Turn the MAIN POWER switch on.</li> <li>Insert the power cord into an AC socket.</li> </ul>
No picture and sound	<ul style="list-style-type: none"> <li>The setting of the input source is not correct.</li> <li>RGB/Video/Audio wiring to projector is not correct.</li> </ul>	<ul style="list-style-type: none"> <li>Set the correct input using the input select button of the projector or the remote control.</li> <li>Connect the cable to correct input/output source.</li> </ul>
Sound is heard with no picture	<ul style="list-style-type: none"> <li>RGB/Video wiring to projector is not correct.</li> <li>The brightness is set fully to dark.</li> </ul>	<ul style="list-style-type: none"> <li>Connect the cable to correct input/output source.</li> <li>Press the MENU button and increase BRIGHTNESS.</li> </ul>
Picture is displayed with no sound	<ul style="list-style-type: none"> <li>Audio wiring to projector is not correct.</li> <li>The volume is set to minimum.</li> <li>The unit is muted.</li> </ul>	<ul style="list-style-type: none"> <li>Connect the cable to correct input/output source.</li> <li>Press the VOL button and increase VOLUME.</li> <li>Press the MUTE button.</li> </ul>
Color is weak and tint is incorrect	<ul style="list-style-type: none"> <li>The color and tint have been adjusted incorrectly.</li> </ul>	<ul style="list-style-type: none"> <li>Adjust the color and tint correctly.</li> </ul>
Picture is dark	<ul style="list-style-type: none"> <li>The brightness and contrast has been adjusted incorrectly.</li> <li>The lamp needs to be replaced.</li> </ul>	<ul style="list-style-type: none"> <li>Adjust the brightness and contrast correctly.</li> <li>Replace the lamp with a new one.</li> </ul>
Picture is not clear	<ul style="list-style-type: none"> <li>Projector is out of focus.</li> </ul>	<ul style="list-style-type: none"> <li>Adjust the focus.</li> </ul>
LAMP indicator lights red.	<ul style="list-style-type: none"> <li>Lamp will not ignite.</li> </ul>	<ul style="list-style-type: none"> <li>Turn off power and let cool for 20 minutes, then restart.</li> <li>If problem persists call your dealer.</li> </ul>
LAMP indicator blinks red.	<ul style="list-style-type: none"> <li>Air filter door on bottom of case is open.</li> </ul>	<ul style="list-style-type: none"> <li>Ensure air filter door is closed.</li> </ul>
TEMP indicator lights red.	<ul style="list-style-type: none"> <li>Temperature inside projector is too hot.</li> </ul>	<ul style="list-style-type: none"> <li>Do not block the ventilation holes.</li> <li>Clean air filter</li> </ul>
TEMP indicator blinks red.	<ul style="list-style-type: none"> <li>Cooling fan may be obstructed by metal screen under foam air filter.</li> </ul>	<ul style="list-style-type: none"> <li>Align metal screen.</li> <li>If fan blade is still obstructed, call service.</li> </ul>

## 7.2 Message/Solution Table

Error Message Displays	Cause	Solution
NO INPUT IS DETECTED.	The projector is not detecting a signal.	Check cable connections to input device. Input device not connected to this input mode, switch to next mode.
SYNC IS OUT OF RANGE.	The horizontal frequency of input signal exceeds projector capability.	Switch projector to correct resolution. See Appendix A.5
CHANGE THE LAMP. CALL A MAINTENANCE PERSON.	Lamp operation time is greater than 1,900 hours.	Change the projector lamp and reset the lamp operation hours to zero.
CHANGE THE LAMP. CALL A MAINTENANCE PERSON. THE POWER WILL TURN OFF AFTER 20 HOURS.	Lamp operation time is greater than 1,980 hours which leaves 20 hours of lamp time.	Change the projection lamp and reset the lamp operation hours to zero.
CHANGE THE LAMP. (Blinking message)	Lamp operating time is greater than 2000 hours. Safety feature shuts projector down after 10 minutes.	Change the projector lamp and reset the lamp operation hours to zero.
CHECK THE AIR FLOW.	Air flow to cooling fan is blocked.	Clear air flow path to fan and clean air filter.



# Section 8: Accessories

ENGLISH

## 8.1 Service Information

For product information, product assistance, service information, or to order accessories, please call:

In U.S. or Canada: **1-800-328-1371**

In other locations, contact your local 3M Sales office.

## 8.2 Accessories

	<b>Part Number</b>
Ultra-high performance lamp module, 150 W . . . . .	78-6969-8588-3
Power cord (US) . . . . .	26-1011-8852-7
Power cord (UK) . . . . .	78-8118-3304-1
Power cord (Germany) . . . . .	78-8118-3303-3
VGA cable . . . . .	78-8118-3401-5
MAC adapter . . . . .	78-1011-3308-2
S-video cable . . . . .	26-1011-3419-0
3-conductor video/audio cable . . . . .	78-8118-3306-6
Serial mouse cable . . . . .	78-8118-3426-2
PS/2 mouse cable . . . . .	78-8118-3424-7
ADB mouse cable . . . . .	78-8118-3425-4
Stereo mini jack cable . . . . .	26-1012-0683-2
Remote Control . . . . .	78-8118-3534-3
Ceiling mount . . . . .	XX-XXXX-XXXX-X
Adjustable height suspension . . . . .	78-6969-8312-7
Shipping case . . . . .	78-6969-8584-1
Soft carry case . . . . .	78-6969-8585-8

## Not Included with Basic Packet

	<b>Part Number</b>
RS-232 control cable . . . . .	78-8118-3312-4
Document Camera - 120 VAC 60 Hz (optional) . . . . .	78-6969-8578-3
Document Camera - 220 VAC 50 Hz (optional) . . . . .	78-6969-8724-3

## 8.3 How to Order

Please order these parts through your dealer, or contact 3m Customer Service at the following number:

In U.S. or Canada: **1-800-328-1371**

In other locations, contact your 3M Sales office.

The contents of this manual are subject to revision without prior notice.

3M assumes no responsibility for the infringement of special rights of a third party or other rights that may arise out of the information contained in this manual.

Reproduction of this manual in any form without prior permission is strictly prohibited.

3M will replace the manual if any pages are missing or collated incorrectly.



## Table of Contents

- A.1 Technical Specifications**
- A.2 Dimensions**
- A.3 Projector-to-Screen Distance**
- A.4 Connection to the Video Signal Terminal**
- A.5 Connection to the RGB Signal Terminal**
- A.6 Indicator Status**
- A.7 Connection to the Control Signal Terminal**

## A.1 Technical Specifications

✓ Note

All specifications are subject to change without notice.

Product name		Multimedia projector
Model Name		MP8625
Display system		3 sheets of liquid crystal panels, 3 primary color lights shutter system.
Liquid crystal panel	Panel size	0.9 inches (23 mm)
	Drive system	TFT active matrix
	Number of pixels	480,000 pixels (V600 × H800) per panel. 1.44 million total pixels with 3 panels.
Lens		F/Number: F/2.0 – F/2.3      Focal Length: F = 38.0 – 50.0 mm (1.5" – 2")
Lamp		Ultra-high performance lamp 150W, UHP
Speaker (stereo)		2 x 1 watt
Power supply		AC100 ~ 120V, 5A / AC220 ~ 240V, 2.2A (Universal)
Power consumption		230W
Operating temperature range		32° ~ 95°F (0° ~ 35°C)
Dimensions		9.4 in. (W) x 4.9 in. (H) x 13.2 in. (D) 230 mm (W) x 124 mm (H) x 335 mm (D)
Weight		11 lbs. (4.9 kg)
Input/Output terminal	video signal input terminal	S VIDEO : Mini DIN4-pin terminal VIDEO : RCA Jack terminal AUDIO : RCA Jack terminal
	RGB input/output signal terminal	RGB signal : D-sub 15pin (Female) AUDIO : Stereo mini jack
	Control terminal	D-sub 15pin (Male)



## A.2 Dimension

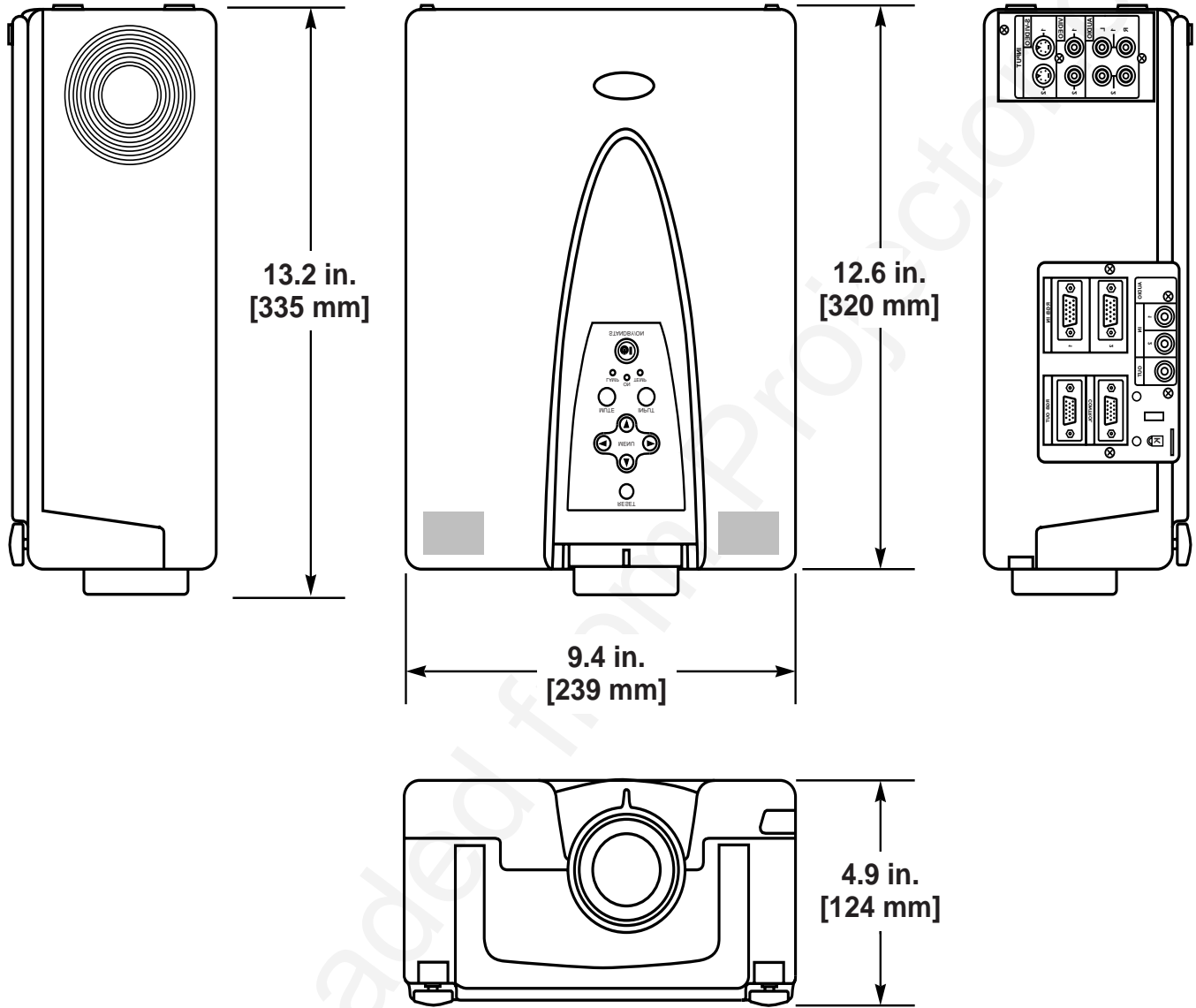

### A.3 Projector-to-Screen Distance

Example of the Multimedia projector and screen installation. Determine picture size and projection distance as illustrated below.

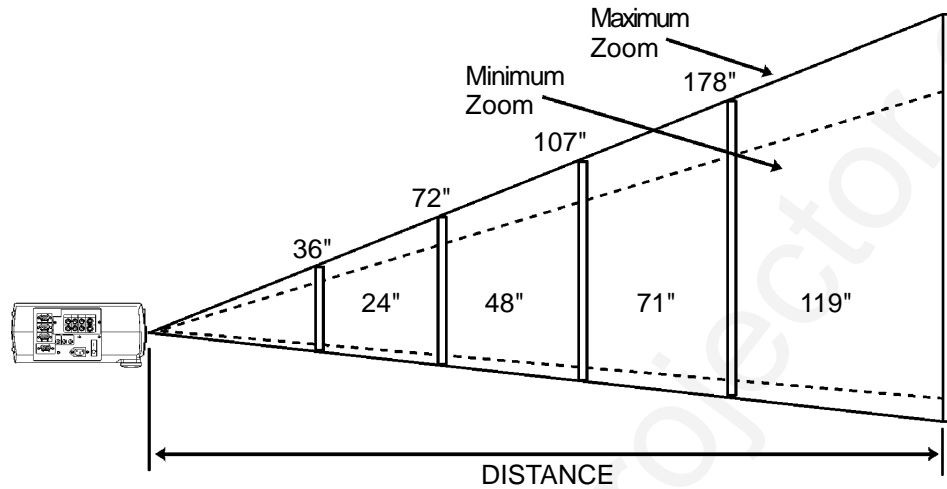

Distance To Screen	Minimum Image			Maximum Image		
	Diagonal	Width	Height	Diagonal	Width	Height
214 cm (7.0 ft)	102 cm (40 in.)	81 cm (32 in.)	61 cm (24 in.)	130 cm (51 in.)	104 cm (41 in.)	78 cm (31 in.)
311 cm (10.2 ft)	152 cm (60 in.)	122 cm (48 in.)	91 cm (36 in.)	191 cm (75 in.)	152 cm (60 in.)	114 cm (45 in.)
408 cm (13.4 ft)	203 cm (80 in.)	163 cm (64 in.)	122 cm (48 in.)	251 cm (99 in.)	201 cm (79 in.)	151 cm (59 in.)
506 cm (16.6 ft)	254 cm (100 in.)	203 cm (80 in.)	152 cm (60 in.)	315 cm (124 in.)	252 cm (99 in.)	189 cm (74 in.)
604 cm (19.8 ft)	305 cm (120 in.)	244 cm (96 in.)	183 cm (72 in.)	376 cm (148 in.)	301 cm (118 in.)	226 cm (89 in.)
750 cm (24.6 ft)	381 cm (150 in.)	305 cm (120 in.)	229 cm (90 in.)	467 cm (184 in.)	374 cm (147 in.)	280 cm (110 in.)
994 cm (32.6 ft)	508 cm (200 in.)	406 cm (160 in.)	305 cm (120 in.)	622 cm (245 in.)	498 cm (196 in.)	373 cm (147 in.)

**✓ Note**

These sizes are ± 1 inch. This is due to variations in the manufacture of the lens. If you are close to one of the endpoints you should verify with your unit that the image is the proper size at the proper distance.

## A.4 Connection to the Video Signal Terminal

### a) Input signal

S-VIDEO signal		Luminance signal	1.0Vp-p, 75 Ω termination
		Chrominance signal	0.286Vp-p (burst signal), 75 Ω termination
VIDEO signal		1.0Vp-p, 75Ω termination	
AUDIO signal	Input	200mVrms, 20 kΩ below (MAX 3.0Vp-p)	
	Output	0~200mVrms, 1k Ω	

### b) Signal input terminal

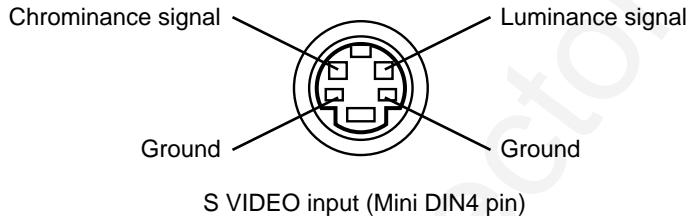

#### ✓ Note

Video input signal terminals have priority in the following order:

1. S-VIDEO input terminal
2. RCA jack (composite) input terminal

## A.5 Connection to the RGB Signal Terminal

### a) Input signal / Output signal

Video signal		Analog 0.7Vp-p 75 Ω termination (Positive polarity)
Horizontal sync signal		TTL level (Positive/negative polarity)
Vertical sync signal		TTL level (Positive/negative polarity)
Composite sync signal		TTL level
Audio signal	Input	200mVrms, 20k Ω below (MAX 3.0Vp-p)
	Output	0 ~ 200mVrms, 1k Ω

### b) Signal input terminal / output terminal

1	Video signal (Red)	9	No Connection
2	Video signal (Green)	10	No Connection
3	Video signal (Blue)	11	Ground
4	No Connection	12	SDA (DDC)
5	No Connection	13	Horizontal/Composite sync signal
6	Ground (for R)	14	Vertical sync signal
7	Ground (for G)	15	SCL (DDC)
8	Ground (for B)		

c) **Example of computer signal**

Resolution HxV	Refresh Rate	Horizontal Frequency	Standard Type	Note	Display Dots HxV
640 x 350	70.1 Hz	31.5 kHz		VGA-1	800 x 490
640 x 400	56.4 Hz	24.8 kHz		NEC PC9800	800 x 560
640 x 400	70.1 Hz	31.5 kHz		VGA-2	800 x 560
640 x 480	85.0 Hz	43.3 kHz	VESA		800 x 600
640 x 480	59.9 Hz	31.5 kHz	VESA	VGA-3	800 x 600
640 x 480	66.7 Hz	35.0 kHz		MAC 13"	800 x 600
640 x 480	72.8 Hz	37.9 kHz	VESA		800 x 600
640 x 480	75.0 Hz	37.5 kHz	VESA		800 x 600
800 x 600	56.3 Hz	35.2 kHz	VESA	SVGA (56 Hz)	800 x 600
800 x 600	60.3 Hz	37.9 kHz	VESA	SVGA (60 Hz)	800 x 600
800 x 600	72.2 Hz	48.1 kHz	VESA	SVGA (72 Hz)	800 x 600
800 x 600	75.0 Hz	46.9 kHz	VESA	SVGA (75 Hz)	800 x 600
800 x 600	85.1 Hz	53.7 kHz	VESA	SVGA (85 Hz)	800 x 600
832 x 624	74.5 Hz	49.7 kHz		MAC 16"	800 x 600
1024 x 768	60.0 Hz	48.4 kHz	VESA	XGA (60 Hz) Compressed	768 x 576
1024 x 768	70.1 Hz	56.5 kHz	VESA	XGA (70 Hz) Compressed	768 x 576
1024 x 768	75.0 Hz	60.0 kHz	VESA	XGA (75 Hz) Compressed	768 x 576

**Note 1: MAC adapter is necessary to set the resolution mode.  
Projector is compatible with 13 inch mode and 16 inch mode.**

**Set all dip switches OFF except those indicated in the chart.**

**For example:**

**MAC 13" mode = switch 1, 5 and 6 are ON**

**MAC 16" mode = switch 2, 5 and 6 are ON**

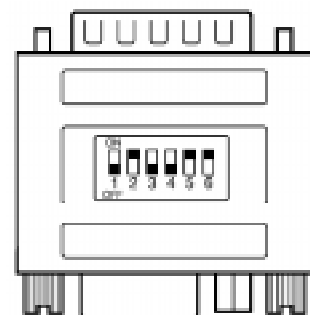

(Example of 16 inch mode)

**Note 2: Some input sources may not be displayed properly because they are not compatible with the projector.**

## A.6 Indicator Status

The ON, LAMP and TEMP indicators will light or blink in the following cases:

	Indicator status	Meaning	Remedy
ON indicator	Lights orange	Standby mode	normal
	Blinks green	During warming up	normal
	Lights green	During operation	normal
	Blinks orange	During cooling down	normal
LAMP indicator	Lights red	Lamp cannot light	Cool projector by power off for 20 minutes.
	Blinks red	Air filter open	Ensure filter is closed.
TEMP indicator	Lights red	Temperature inside too high	Let projector cool 20 minutes. Check air flow and filter.
	Blinks red	Cooling fan not operating	call your dealer

**\*When the LAMP indicator lights or blinks, turn the power off. If the problem persists, contact your dealer.**

## A.7 Connection to the Control Signal Terminal

### a) Mouse emulation

- (1) While the projector and computer are turned OFF, connect the projector and the mouse terminal of computer using an appropriate cable. (PS/2, Serial or ADB)
- (2) Turn ON the projector.
- (3) Turn ON the computer.
- (4) Select the correct mouse driver for the application. See computer's User Manual for this procedure.

#### ✓ Note

In some Notebook computers which have internal pointing device, mouse emulation will not work unless the internal pointing device is disabled. In this case, disable the internal pointing device in BIOS setting. Check the computer's manual for procedure to follow to disable internal pointing device in BIOS setting.

#### ⚠ Caution

Turn off the power to both the projector and computer before connecting. Connect the computer to the control terminal of the projector using the appropriate cable.

### PS/2 mouse

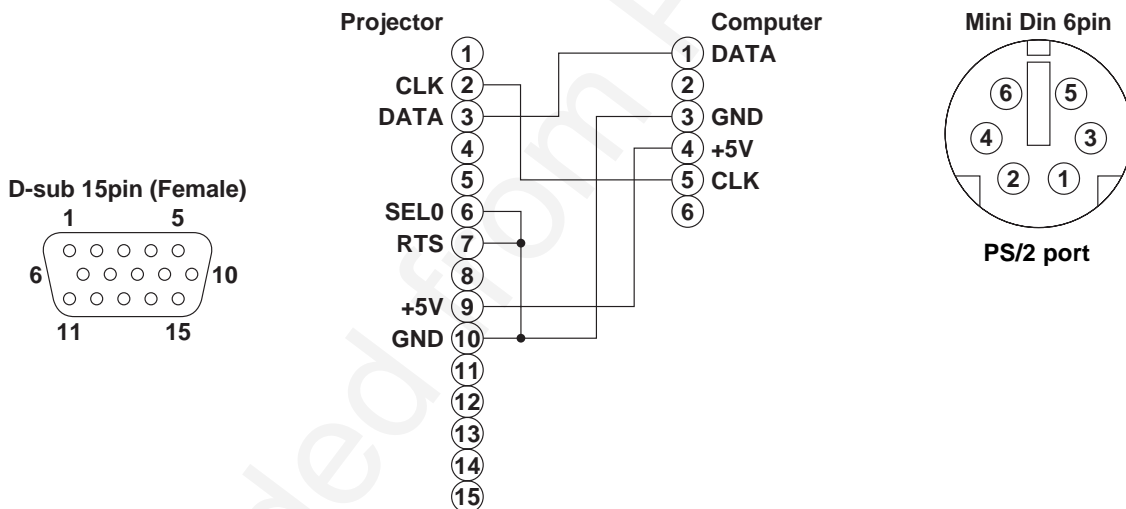

### ADB mouse

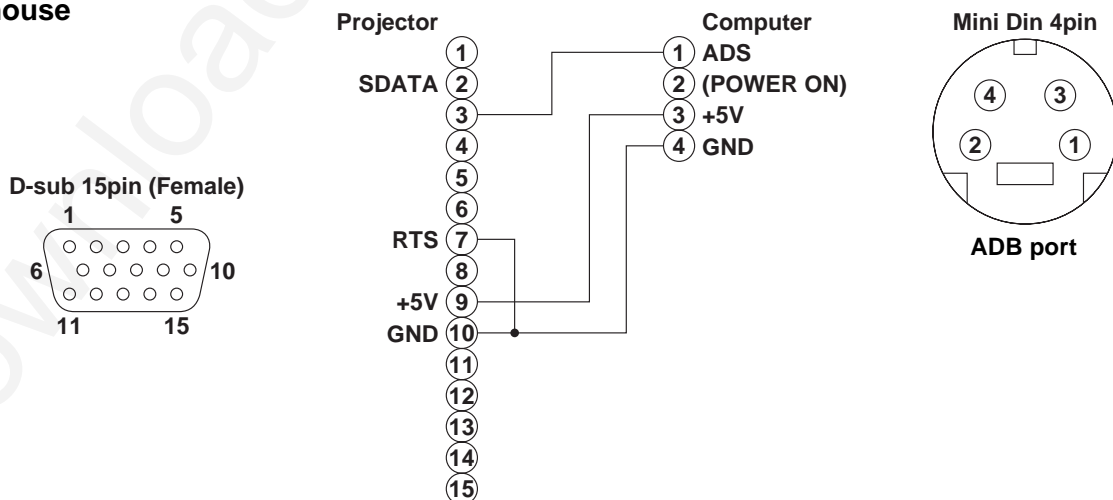

## A.7 Connection to the Control Signal Terminal (continued)

### Serial mouse

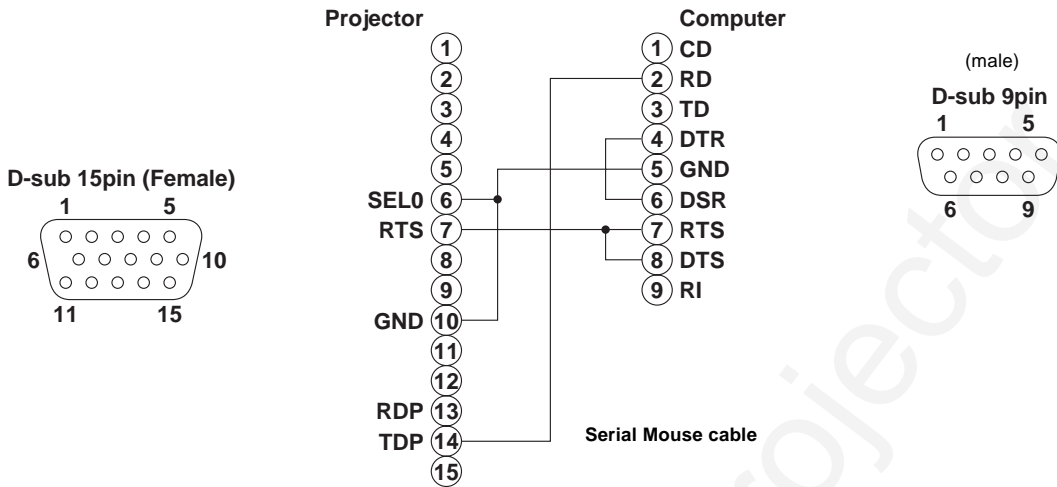

### b) RS-232 Control Cable (not included with basic packout)

This cable is used to directly control the projector without using the Remote Control or Operator's Panel.

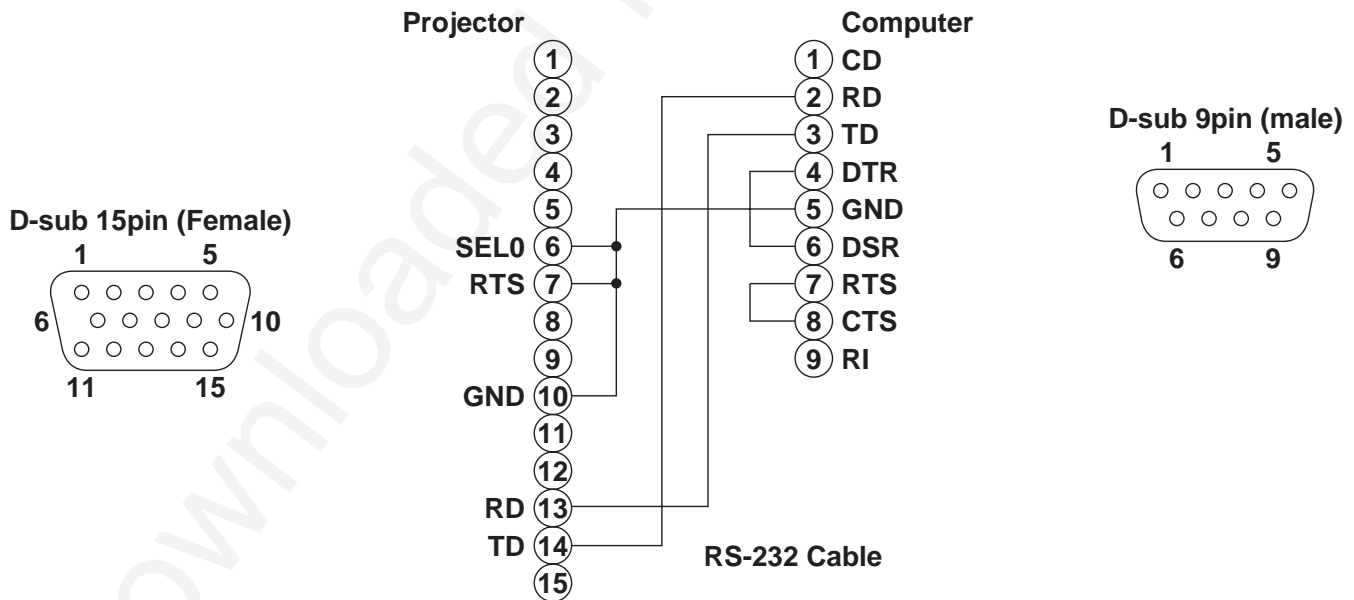

## Serial Command Codes

All numbers in this document are in Hexadecimal. You must send at the same communication setting as the projector and use a null modem serial cable to connect to the projector.

There are four types of messages for the MP8730, 1) ASK, 2) REPLY, 3) SET and 4) DEFAULT.

Ask Code:

User:

20	XX
----	----

XX is the attribute you are checking.

Projector:

1Y	XX	Y bytes of data
----	----	-----------------

This is a reply code. The Y is the number of extra bytes that come after the command. The XX is the same as in the Ask code.

Set Code:

User:

3Y	XX	Y bytes of data
----	----	-----------------

XX is the attribute you are checking. The Y is the number of bytes for the data.

Projector:

1Y	XX	Y bytes of data
----	----	-----------------

This is a reply code. The Y is the number of extra bytes that come after the command. The XX is the same as in the Set code.

### Default Code:

User:

40	XX
----	----

XX is the attribute you are checking.

Projector:

1Y	XX	Y bytes of data
----	----	-----------------

This is a reply code. The Y is the number of extra bytes that come after the command. The XX is the same as in the Ask code.

Errors:

For an error, the projector will reply with the same code that was sent but with a 0 in the first nibble.



## Serial Command Code Table

Function	Command Code	# Bytes	Data Code	Meaning
Mouse	05	1	00 01-7F	Stop mouse function Enable mouse function
Communication	06	1	0X 1X X0 X1 X2 X3 X4	8N1 7N1 1200 bps 2400 bps 4800 bps 9600 bps 19200 bps
Power	11	1	1E 1F	Power off Power on
Mirror	14	1	00 01 02 03	Normal H Invert V Invert H & V Invert
Magnify	15	Set Command 6          Ask Command 1	00 00 00 00 00 00 00 00-3C 05  00 00-0D 04  64 00-20 06  00 01	X-coordinate = First, 2-bytes (left top corner) Y-coordinate = Second, 2-bytes (00 00, 00 00) Magnification = Third, 2-bytes (64 00 is x 8, 20 06 is x1)  Magnify Off Magnify On
Freeze	16	1	00 01	Freeze Off Freeze On
Input	21	1	11 12 21 22	Video 1 Video 2 RGB 1 RGB 2
Video Type	22	2	00 00 00 01 00 02 00 03	Auto NTSC PAL SECAM
Volume	23	1	00-7F	00 - Softest
Mute	24	1	00 01	Mute off Mute on
Brightness	31	3	00 00 00 - 00 00 7F	7F is high end of scale
Contrast	32	3	00 00 00 - 00 00 7F	7F is high end of scale
Color	33	3	00 00 00 - 00 00 7F	7F is high end of scale
Tint	34	3	00 00 00 - 00 00 7F	7F is green end of scale
Sharpness	35	3	00 00 00 - 00 00 7F	7F is sharp end of scale

## Serial Command Code Table (con't)

Function	Command Code	# Bytes	Data Code	Meaning
H. Phase	37	3	00 00 00 - 00 00 1F	
H. Position	38	4	00 00 00 00 - 00 00 7F 01	7F is right end of scale
H. Size	36	4	00 00 02 06 - 00 00 1E 08	1E 08 is wide end of scale
V. Position	3A	3	00 00 00 00 - 00 00 7F 01	7F 01 is down
Blank	41	1	0X 1X bit 0 - 0 bit 0 - 1 bit 1 - 0 bit 1 - 1 bit 2 - 0 bit 2 - 1 bit 3 - 0 bit 3 - 1	Blank off Blank on Blue off Blue on Green off Green on Red off Red on No change Change
Reveal	42	1	0X X1 X4	Stop Reveal down Reveal right  X in down and right is 0 - 7 with 7 being the fastest

Downloaded from Projector.com



All statements, technical information, and recommendations related to Seller's products are based on information believed to be reliable, but the accuracy or completeness thereof is not guaranteed. Before utilizing the product, the user should determine the suitability of the product for its intended use. The user assumes all risks and liability whatsoever in connection with such use.

Any statements or recommendations of the Seller which are not contained in the Seller's current publications shall have no force or effect unless contained in an agreement signed by an authorized officer of Seller. The statements contained herein are made in lieu of all warranties, expressed or implied, including but not limited to the implied warranties of merchantability and fitness for a particular purpose which warranties are hereby expressly disclaimed.

SELLER SHALL NOT BE LIABLE TO THE USER OR ANY OTHER PERSON UNDER ANY LEGAL THEORY, INCLUDING BUT NOT LIMITED TO NEGLIGENCE OR STRICT LIABILITY, FOR ANY INJURY OR FOR AN DIRECT, INDIRECT, INCIDENTAL OR CONSEQUENTIAL DAMAGES SUSTAINED OR INCURRED BY REASON OF THE USE OF ANY OF THE SELLER'S PRODUCTS.

Let us help you make the most of your next presentation. We offer everything from presentation supplies to tips for better meetings. And we're the only transparency manufacturer that offers a recycling program for your used transparencies. For late-breaking news, handy reference and free product samples, call us toll-free in the continental United States and Canada from 7:30 a.m. to 5:30 p.m. (CST) or visit our Internet Website.



**800-328-1371**



**<http://www.mmm.com/presentations>  
e-mail: [presentations@mmm.com](mailto:presentations@mmm.com)**

**3M Austin Center**  
Building A145-5N-01  
6801 River Place Blvd.  
Austin, TX 78726-9000

**3M Canada**  
P.O. Box 5757  
London, Ontario  
N6A 4T1

**3M Mexico, S.A. de C.V.**  
Apartado Postal 14-139  
Mexico, D.F. 07000  
Mexico

**3M Europe**  
Boulevard de l'Oise  
95006 Cerge Pontoise Cedex  
France

  
*Printed on 50% recycled wastepaper,  
including 10% post-consumer*

Litho in USA  
© 3M 1998 78-6970-8926-2  
Rev. A

## **PLEASE READ**

This manual is provided as a free service by Projector.com.

We are in no way responsible for the contents of the manual. We do not guarantee its accuracy and we do not make any claim of copyright. The copyright remains the property of their respective owners.

## **ABOUT PROJECTOR.COM**

Projector.com (<http://www.projector.com>) is your review and buying guide resource for DLP and LCD video projectors.

Visit the site to read the latest projector news and reviews, read and comment on projector specifications, download user manuals and much more.